

Tools and implements

To assemble this kit you will require following items – not included: Allen key SM1,5, tweezers, needle-nose pliers, Allen key SW2,5, Torx-screwdriver 8,10,20. (These items can be ordered from the shop)

Included in the kit are the following items: 1 small syringe of ceramic paste (very dry), 1 small syringe of oil Aeroshell Fluid 12, 1 small syringe of super glue (hazardous), 1,5mm drift punch (to remove mounted adjusting pins), holding platelets (white) to mount adjusting pins

Assembly

1 – Carefully insert a bearing (3) in each rocker arm (1) by hand.

2 – To glue the bearings begin by degreasing all outer rims of bearings and inner surfaces of the bearing seats using ethyl alcohol on a cloth. (WARNING: wear protective goggles and gloves during gluing, super glue is very hazardous!!!) Insert three bearings (4) in the side frames (9 + 10) so as to have them flush with the outer side (countersunk side of the funnel is the outer side (29)). Apply the super glue to the edge between the bearings and the countersink of the bore hole using a toothpick (Apply glue sparingly! The glue gets sucked into the gap by itself. Then glue in bearings (2) 11x4mm for the crank shaft.

3 – Lay the displacement piston cover (20) flat side down on the table and press in the displacement piston (19) vertically until you reach the table surface. Apply some lacquer to the inside thread of the displacement piston (19) using a toothpick, then screw into the displacement axis (18) until you reach the limit stop. Carefully remove excessive lacquer with a cloth (approx. 2 hours of drying time).

4 – Insert the assembled displacement piston (18/19/20) in the cooling cylinder (22). If you hold the cylinder vertically, the displacement piston should fall into it by itself without jamming. It is important to keep all parts clean!

5 – Place the heating cylinder (23) in the middle of the cooling cylinder (22) and screw tight with the 4 Allen screws (24).

6 – Use the white plastic press fitting tool to place the pin (16) on the sunken side of the cylinder (17) and attach connection rod using needle-nose pliers.

7 – Rub a small amount of white ceramic paste (open with wire cutters) between your thumb and index finger until the paste is almost invisible. Now use your index finger to apply a wafer thin coat on the working piston (17). Insert the piston (17) in the cooling cylinder (22) and move back and forth. The piston (17) should not scratch or jam! Apply a droplet of oil from the provided syringe onto the displacement axis (18).

8 – Affix the short connection rod (15) to the working piston (17) via the pin (16). (Use the white press fitting tool)

9.- Attach the assembled connection rod (15) to the rocker arm (1). Push a black plastic bush (11) into the connection rod (15) from the back and screw tight from the front with a screw (12). Only tighten lightly with a torque of 3cNm or you risk crushing the plastic bush!

10 – Plug a flywheel (25) on the from side frame (9) so that it sits flush with the outside of the axis of the crank shaft. Lightly tighten the grub screw (26).

11- Screw the M3x3 grub screws (26) into the 3 aluminum wheels, flywheel (25) and right drive wheel (35).

12- Press the locking rings into the 4 axes.

13- Insert the steering column (40) into the radiator grille (41) from the bottom and affix the steering wheel (39) from the top, screwing it tight with the screw (8) (hold steering column in place with pliers)

14 - Stick the cooler logo (43) in the depression to the front of the radiator grille (pull off paper).

15- Introduce the steering fork (46) into the seat (42) from the bottom, tighten the grub screw with pin (31) as much as you can, then untighten slightly so as to allow the steering fork to rotate. Insert the belt wheel 25x1.5 (5) before screwing on the wheel.

16- Insert bearing (4) into steering wheel in front (37) and screw to the front axle (44) and to the steering fork (46) with the Torx counter-sunk screw. (It looks like a mushroom head)

17- Lightly screw the pre-assembled cooling cylinder (2) to the right side frame (to the right in the direction of driving) using the Torx 10 countersunk screw (51).

18- Attach the rocker arm axis (14) to the top right of the side frame using the Torx counter-sunk screw M3x6 (29).

19- Push spacer (32) onto the rocker arm axis (14).

20- Push the pre-assembled rocker arm (1) onto the flat flush side of the rocker arm axis (14).

21- Push spacer (33) onto the rocker arm axis (14).

22- Push the longer axis of the crank shaft (13) through the bearing (2) attached to the right side frame.

23- Carefully press the connection rod (21) of the crank shaft with the displacement axis (18) into the pin (16) using the white plastic press fitting tool and needle-nose pliers. (Tip: on one side of the displacement axis the bore hole is sunken 1,5mm, please insert the pin from this side.) Avoid damaging the bearing surface of the displacement axis at all costs! In the case of accidental damage, you may send in the damaged part and obtain a new displacement axis for 8€ (however we need to measure the old one).

24- Screw the leather chair (42) to the right side frame (9) using 2 Torx 10 locker counter-sunk screws (52).

25- Insert the burner plate (45) into the right side frame.

26- Carefully fit the left side frame (10), then push over the crank shaft axis and bearings until it sits flush with the cooling cylinder (22). Also insert the burner plate (45).

27- Lightly screw the cooling cylinder (22) with the screws (51).

28- Screw the rocker arm axis tight with the Torx counter-sunk screw (29).

29- Screw the chair tight with 2x screws (51) (Connection rod (27) must stand upward)

30- Push the pre-assembled axes for the belt pulleys (47) from the left side frame (10) through the bearings (4), then lay the left side frame on the table so as to attach belt pulleys (47) to the axis from the other side, following the drawing and using grub screws (26). See also the drawings on the homepage. Use the small belt nr. 7 (42x1.5) from the topmost belt pulley (small diameter) to the second belt pulley (large diameter), all other belts are 45mmx1.5).

31- Push the pre-assembled axis (48) through the left wheel (36). Now plug the spacer wheel (34) at the top over the axis. Now push the lot through the left side frame (10) (Ø4.2 hole) and right side frame (9). Now you can push in a spacer (57) and a belt pulley with a small pulley tie from the other side (right) onto the axis (48). Now attach the large pulley flush with the axis (26). Finally push the belt pulley onto the brass wheel and attach them (26). Screw connection rod 12/11/1 + 12/15/11 to the rocker arm (1).

32- Lightly screw the headlamps and spacer (52) to the Leather chair hole (42) with the screw (53). Repeat process from the other side. It may be necessary to move the chair slightly to be able to screw them in. Now affix the radiator grille (41) to the leather chair with 12mm screws (59). When all screws are correctly positioned you may tighten them properly.

33- Mount the flywheel (25) onto the crank shaft axis flush with the left side panel and attach (26). Mount the black drive wheel from the other side and leave about 0.2mm play. Now you may insert the topmost belt drive (6). For the first test, please detach the belt drive and run without belt drive. (= **after 20 sec quickly and strong** push the left flywheel forward(25) to see if the motor functions run properly (after 20 seconds of heating time)).

34- Plug in the Prussian picked helmets, press in with pliers if necessary.

Start operating the motor

WARNING: The motor should only be operated under constant supervision of persons 18 or older. No flammable objects should be placed in the vicinity of the functioning motor. Do not touch the motor as this could burn you. Be careful when handling ethyl alcohol. Never leave a bottle of ethyl alcohol open. Inappropriate operation of the Stirling motor presents a fire hazard!

Operating instructions

CAUTION: Always close and put away the alcohol bottle. Ethanol can cause severe eye irritation (in case of accident, rinse eyes with water). Let the burner cool down to room temperature after each use. Fill the alcohol burner up to the maximum ring filling height, otherwise there is a risk that alcohol will leak out of the burner. Ignition can then lead to a flame. Alcohol can damage the paint. The legal requirements for open fire apply.

1 - Place the engine in a draft-free location.

2 - Remove the spirit burner and fill with 94-96% alcohol / ethanol to the lower ring mark.

3 - Light the wick.

4 - Approx. Preheat for 30 seconds.

5 - Turn the flywheel until the engine runs by itself.

• Never run the engine unattended.

Allow engine and spirit burner to cool to room temperature (19-21 ° C) after use! (Models are NOT suitable for continuous running)

The engine should be stored dust-free. Even the smallest dirt can cause the engine to stop. The fits are located in the H7 area. All mechanical, moving parts must be easy to move, otherwise the engine will not run! Caution when disassembling - many parts have wall thicknesses of less than 0.25 mm.

MAINTENANCE:

After an hour of running, please remove and clean the piston and cylinder

Instructions can be found here on the SUPPORT website

<http://www.boehm-stirling.com/support.html>

What to do if the engine is not running?

• Check the smooth operation of all mechanical components.

• Are the black tins too tight?

• Has too much paste been applied?

• Has oil spilled onto the working piston? (After longer terms of non-use possible) please dry the piston with cloth as well as the cylinder inside.

If you have any technical questions, please contact us

E-mail: info@stirling-technik.de

Internet: www.boehm-stirling.com

The function principle of the Stirling motor

The burner heats the air that circulates in a closed circuit. Due to thermal expansion, the working piston and flywheels are set in motion. When the working piston travels in the direction of the wheels, the displacement piston is pushed away from the cooling rib part in the heating cylinder. Since the displacer has no seal, the hot air streams past its outer surface and past the cooling ribs in the cylinder. The temperature in this area is approx. 300°C lower, producing a diminishing of volume and creating a vacuum that sucks the working cylinder back, maintaining the flywheel's motion. The rotational movement pushes the displacement piston back towards the cooling ribs and the cool air gets pushed out of the heating cylinder. The air is then reheated, expands and produces work once more.

Auto-Stirling A1

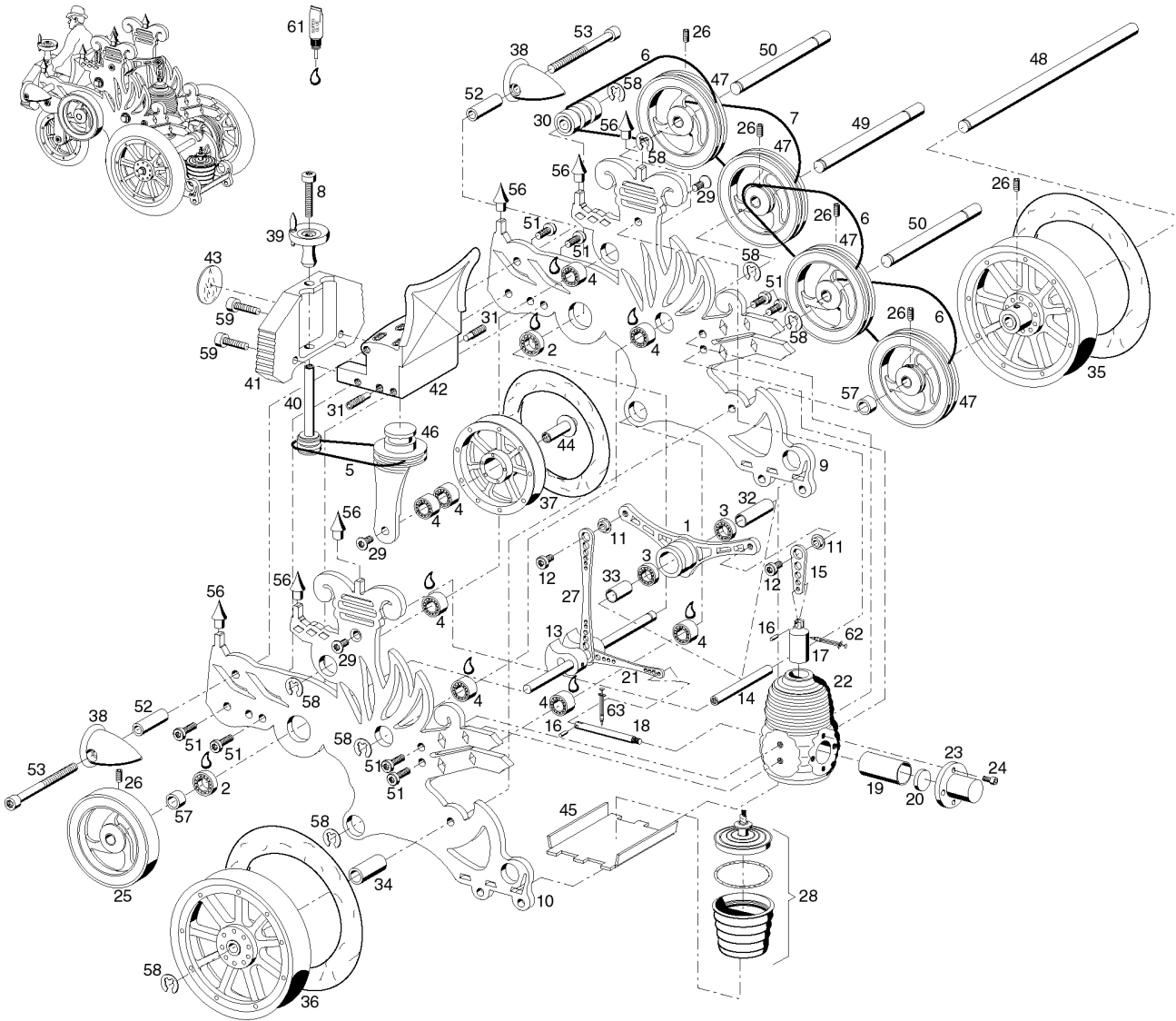

Stückliste/Ersatzteilliste
Auto-Stirling A1

Bill of material
Car-Stirling A1

Bild/Nr. Ill. No.	Benennung Part No.	Abm. Bemerk. Diment. Remarks	Stück Pieces	Denomination
1	Kipphebel		1	Rocker arm
2	Kugellager	∅ 11x4mm	2	Ball bearing
3	Kugellager	∅ 9x2,5mm	2	Ball bearing
4	Kugellager	∅ 9x4mm	8	Ball bearing
5	O-Riemen Lenkrad	∅ 25x1,5mm	1	Belt wheel
6	O-Riemen Antrieb	∅ 45x1,5mm	3	Belt drive
7	O-Riemen Antrieb	∅ 42x1,5mm	1	Belt drive
8	Linsenkopfschraube Lenk.	M3x16 TX10	1	Torx counter-sunk screw
9	Seitenteil rechts		1	Side frame, right
10	Seitenteil links		1	Side frame, left
11	Schwarze Plastikbüchse		2	Black plastic bush
12	Linsenkopfschraube	M2,5x4 TX8	2	Torx counter-sunk screw
13	Kurbelwelle montiert		1	Crank shaft ass.
14	Kipphebelachse		1	Rocker arm shaft
15	Pleuel kurz	22mm	1	Connecting rod, short
16	Passstift	∅ 1,5x4mm	2	Pin
17	Arbeitskolben	∅ 9x18,3mm	1	Working piston
18	Verdrängerachse	∅ 4x31mm	1	Displace axle
19	Verdrängerkolben	∅ 12x27,6mm	1	Displace piston
20	Verdrängerkolben Deckel	∅ 11,6x1,5	1	Displace piston cover
21	Pleuel mitte Kurbelwelle	39mm	1	Connecting rod, medium
22	Kühlzylinder (Messing)	∅ 40x52,5mm	1	Cooling cylinder (brass)
23	Heizzylinder	∅ 25x21mm	1	Heating cylinder
24	Inbusschraube	M3x8mm, SW2,5	4	Sockethead screw
25	Schwungrad	∅ 40x12mm	1	Flywheel, brass
26	Madenschraube	M3x3mm, SW1,5	6	Grub screw
27	Pleuel lang Kurbelwelle	62mm	1	Connecting rod, long
28	Brennerdose mit Deckel	∅ 30x35mm	1	Burner case with wick
29	Senkschraube	M3x6mm, TX10	3	Torx counter-sunk screw
30	Antriebsrad schwarzes Plastik	∅ 10x14mm	1	Drive wheel, black plastic
31	Madenschraube mit Zapfen	M3x10mm	2	Grub screw with pin
32	Distanzbüchse	12mm	1	Spacer
33	Distanzbüchse	8mm	1	Spacer
34	Distanzbüchse Rad	16mm	1	Spacer
35	Antriebsrad rechts	∅ 75x13,8mm	1	Drive wheel right
36	Lauf rad links	∅ 75x8,6mm	1	Wheel left
37	Steuerrad vorn	∅ 51x10mm	1	Steering wheel in front
38	Scheinwerfer	∅ 17,5x22,7mm	2	Headlamp
39	Lenk rad mit Knauf	∅ 16,5x23,7mm	1	Wheel
40	Lenksäule	∅ 11x37,7mm	1	Steering column
41	Kühlergrill	47x34x8	1	Radiator grille
42	Ledersessel	49x38,7x32	1	Leather armchair
43	Kühlerlogo	∅ 16,3x11mm	1	Cooler logo
44	Vorderradachse	∅ 9,7x13mm	1	Front axle
45	Brennerplatte	34x37mm	1	Burner plate
46	Lenkgabel	∅ 25x43,3mm	1	Steering fork
47	Riemenrad	∅ 40x8mm	4	Belt pulley
48	Antriebsachse	∅ 4x86,6mm	1	Drive axle
49	Achse für Riemenrad	∅ 4x48mm	1	Axle
50	Achse für Riemenrad	∅ 4x46mm	2	Axle
51	Linsenkopfschraube	M3x6mm, TX10	8	Torx counter-sunk screw
52	Distanzhülse Scheinwerfer	∅ 5x13mm	2	Spacer
53	Zylinderkopfschraube	M3x30mm	2	Cylinder head screw
56	Preußische Pickelhaube	∅ 7x12mm	6	Picked helmet
57	Distanzbüchse Antriebsrad	∅ 6x4,5x3mm	2	Spacer
58	Sicherungsscheibe	3,2mm	8	Lock washer
59	Linsenkopfschraube Kühler	M3x12, TX10	2	Torx oval-head screw
61	Sekundenkleber	SUPER GLUE	1	Ball bearing adhesive
62	Keramikpaste weiss (fest)		1	White ceramic grease
63	Öl für Verdrängerachse		1	Oil